



## Installation Instructions for the garage door operator

# TM 60



# Content

## Information and Remarks

- Directives and Regulations
- Use of the operators
- Garage Doors
- The installers declaration of conformity
- Older Garage Doors

### **Important Information for the Installer 3**

- Instruction for the users

### **Security Advises for the Installation 4**

## Installation

### **Different Conditions for Installation 5**

- Minimum space above the garage door
- Door Arm Extension
- C-Rail Extension

### **Pre-Mounting the operator 6**

### **Installing the operator 6**

- Minimum head room above the door

### **Adjusting the running-length blocks 8**

### **The Emergency Release 9**

- When there is a second entrance to the garage
- When the garage door is the only entrance

## Printed Circuit Board: Adjustments and Connections

### **Devices for Adjustments 10**

- TEST/RUN-Button (1)
- LERN/LEARN-Button (2)
- Jumper "KRAFT/PRESSURE" (3)
- Combined TEST + LERN button functions

### **Programming Running-Length and Force 11**

- Information
- 1.) Adjusting the running-length blocks
- 2.) Starting the programming-mode
- 3.) Start the learning-cycle
- Quick Reference

### **Special Functions 12**

- Readjusting the CLOSING soft-stop
- Readjusting the time for the internal light
- Setting the pre-warning ON/OFF

### **External Connections 13**

- Push Button and Key Switch
- Photo-Cell
- 24V DC Supply
- Receiver-Module

### **LED-Lamps 14**

- LED "TEST"
- LED "Diag"
- LED "Vp"

## Remote Control

### **Programming the Hand Transmitters 15**

- Basics
- Programming Transmitter and Receiver

### **Additional Information 16**

- Criteria influencing the range
- Use with a HomeLink® System

## Technical Information

### **Technical Data 17**

### **Wiring 17**

- External connections
- Internal Wiring

### **Troubleshooting 18**

- Error Messages
- Error messages via the operator's light
- Additional messages only via the LED "Diag"
- If... then...

## Declaration of Conformity

## Important Information for the Installer

**It is within legal regulation and without restriction, to use a Seip door operator with any garage door that has been approved for use with other certified door operators!**

### Directives and Regulations

The garage door operator TM60 complies to the latest European directives and regulations. The declaration of conformity is enclosed at the end of these instructions.

### Use of the operators

The operators were designed for the use with up-and-over doors (tilting and canopy-type) and sectional doors. All garage doors need to be maintained before automation. The door must be easily opened and closed by hand. A garage door must not be automated unless it is easy to open and close manually.

### Garage Doors

In January 2001 the European regulations EN12604 and EN12605 became compulsory for garage doors. Before installing an automatic door operator it must be assured that the garage doors applies to these regulations (the information can be obtained from the manufacturers' declaration of conformity). A Seip door operator may be installed to any door that complies to the regulations. Should a garage door not be compliant then please refer to the chapter „older garage doors“.

### The installers declaration of conformity

No matter whether a door operator was delivered together with a garage door or separately, the installer must issue a declaration of conformity for the complete installation.

With this declaration the installer assures, that the installation was made according to the instructions given by the manufacturers (e.g. the installation instructions of the garage door and the operator). This declaration can only be issued by the installer and may not be issued from the manufacturer!

If both components comply to the directives and the installation was made as to the manufacturers instructions the whole installation will normally be CE-compliant.

### Older Garage Doors

When automating an older garage-door the TS-series will still comply to the regulations - through the automatic force setting the requested values for forces and reversion will be according to the regulations.

But it needs to be taken in consideration that most older garage doors do not meet the regulations EN 12604 and EN 12605 - especially regarding security features. They might still have sharp edges bearing the danger of severe injuries - for example sectional doors might not have a finger protection between the sections. Unfortunately the entire regulations do not mention how to handle the automation of such an older garage door - the danger basically is not the automation but the construction of the door.

Therefore we strongly recommend to

- check the garage door for sharp edges bearing danger when the door is moving; take any necessary action to avoid the dangers and make the door safer
- check the doors' springs and readjust them if necessary
- grease or oil the pivotal points and rollers of the garage door
- check that the door may be easily used by hand



If, however, the dangers cannot be avoided we recommend to use the automatic pre-warning function of the operator. The operators' lighting will then be blinking for approx. 5 sec. before every movement of the garage door. People inside the garage will be warned before the opening and can step back from the garage door in time.

### Instruction for the users

Please instruct the users as follows:

- Use of the hand transmitter
- Use of the emergency release in case of a power failure
- Hand over the separate „User Manual“ to the customer
- Inform the user about the Security Advises in the User Manual

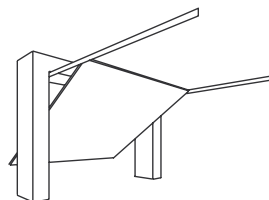

Up-and-over door

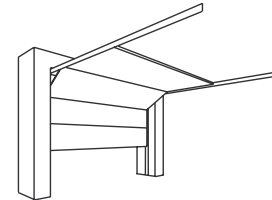

sectional door

## Security Advises for the Installation

### Important Safety Instructions for Installation

**WARNING: INCORRECT INSTALLATION CAN LEAD TO SEVERE INJURY**

**Follow all Installation Instructions.**

- Read page 3 of this instruction carefully before the installation
- Before installing the drive, remove unnecessary ropes from the existing installation
- Maintain the garage door according to the advises on page 3 and to the door manufacturer's manual
- If possible, install the drive at a height of at least 2,10 m and the manual release at a height less than 1,80 m
- Locate the push-button within sight of the door but away from moving parts and at a minimum height of 1,50 m
- Fix the label warning against entrapment next to the push-button
- The label fixed to the manual release may not be removed
- After installation, ensure that the mechanism is properly adjusted and that the drive reverses when the door contacts a 40 mm high object placed on the floor.

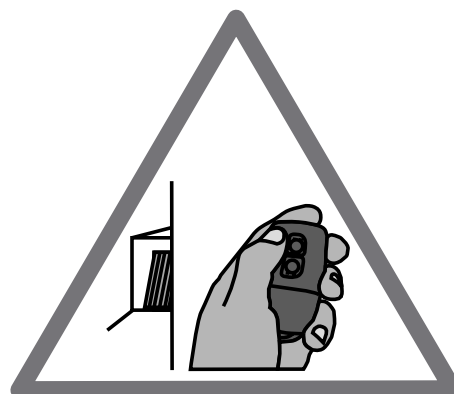
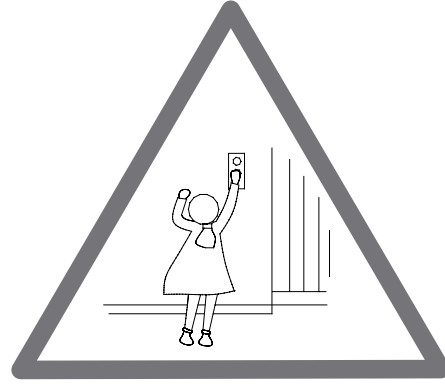

## Different Conditions for Installation

### Minimum space above the garage door

35mm Minimum

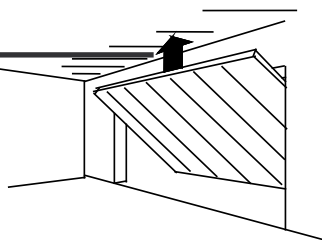

Before installing the operator you should check the garage for the conditions of installation. You will need optional extras in either of the following situations:

### C-Rail Extension

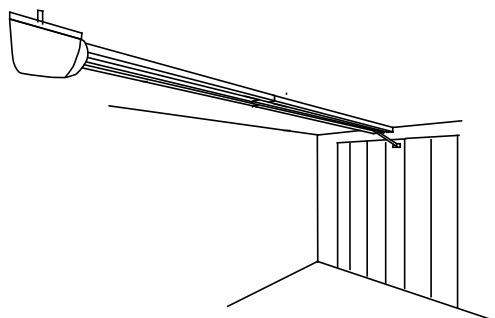

If the garage door is higher than 2.250 mm you will need a c-rail extension. Two sizes of extensions are available: 500mm and 1.000 mm.

The operator may be extended by a maximum of 1.500mm - the maximum height of a garage door is 4.150mm.

### Door Arm Extension

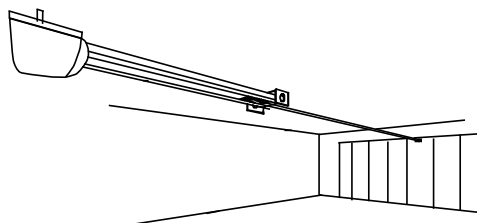

Should the minimum space between the garage door and the ceiling be smaller than 35mm then a door arm extension is needed. For an extension you can use a metal beam from any DIY-market. The beam should not be shorter than the door's height.

## Pre-Mounting the operator

During this procedure be careful not to twist the chain. **Therefore do not lift the parts - slide them along the floor.**

1. The operator is laying unpacked in front of you. The motor-head unit is on your right hand side.
2. Lay part (1) to the front.
3. Fix through pushing the C-profile coupling piece (2) over it all the way home.
4. Slide C-rail part (3) in front of part (1)
5. Set part (3) in the C-rail coupling piece (4) at an angle, inserting it from above as shown.
6. Press down part (3) to tension the chain.
7. Turn around the operator and screw in the milled nuts into the C-rail coupling pieces.

Your operator now is readily premounted for installation.

The chain has been pretensioned in the factory; **do not change the chain tension!**

### ATTENTION:

The TM60 is equipped with a fully automatic measurement for the required running length. When shipped the operator is programmed with a standard running length for factory testings. If you want to run the operator for testing purposes you must fix the blocks inside the c-rail by tightening the screws. **A test run may only be done after making sure, that the blocks are fixed properly. Otherwise damaged might apply to the operator!**

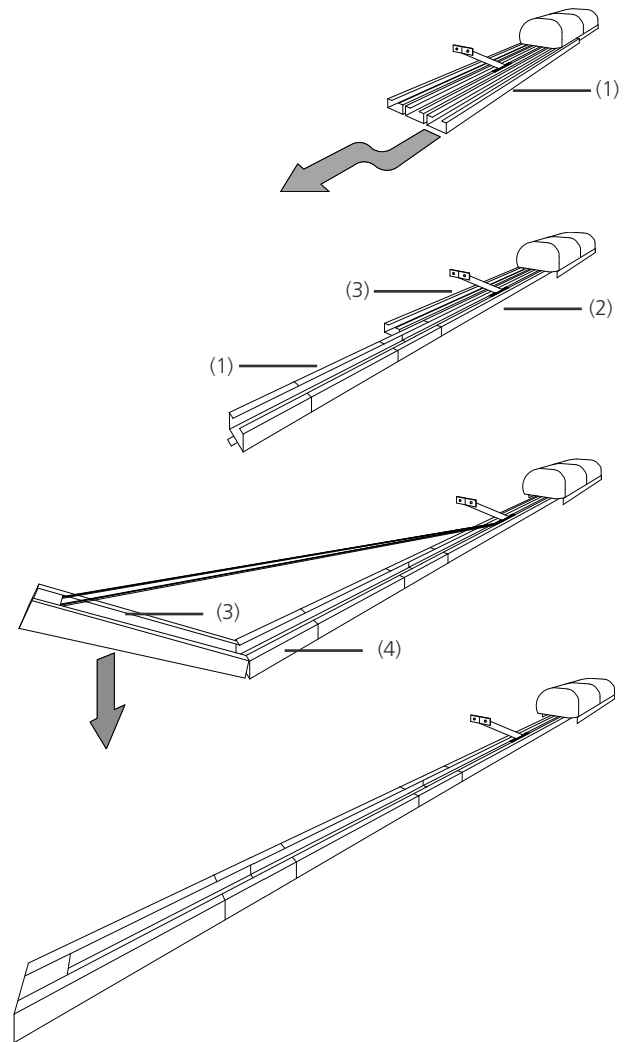

## Installing the operator

### Minimum head room above the door

Measure the distance between the ceiling and the highest point reached by the garage door (1).

The minimum-headroom necessary for mounting the operator is 35 mm. If there is less headroom please pay attention to page 5.

The front fixing angle can be mounted either at the lintel or at the ceiling.

1. Measure the middle of your garage door and make a mark on the lintel and the top of your door (2+2a).
2. Fix the front fixing angle in the middle either at the lintel or at the ceiling. (We recommend the lintel if possible) (2+2a).

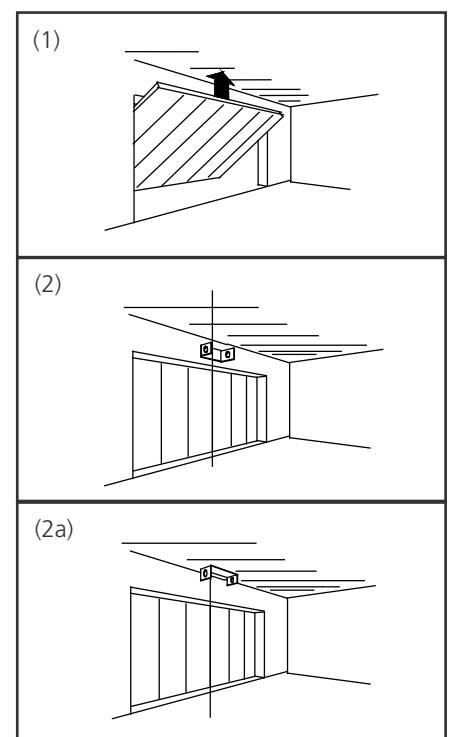

## Installing the operator

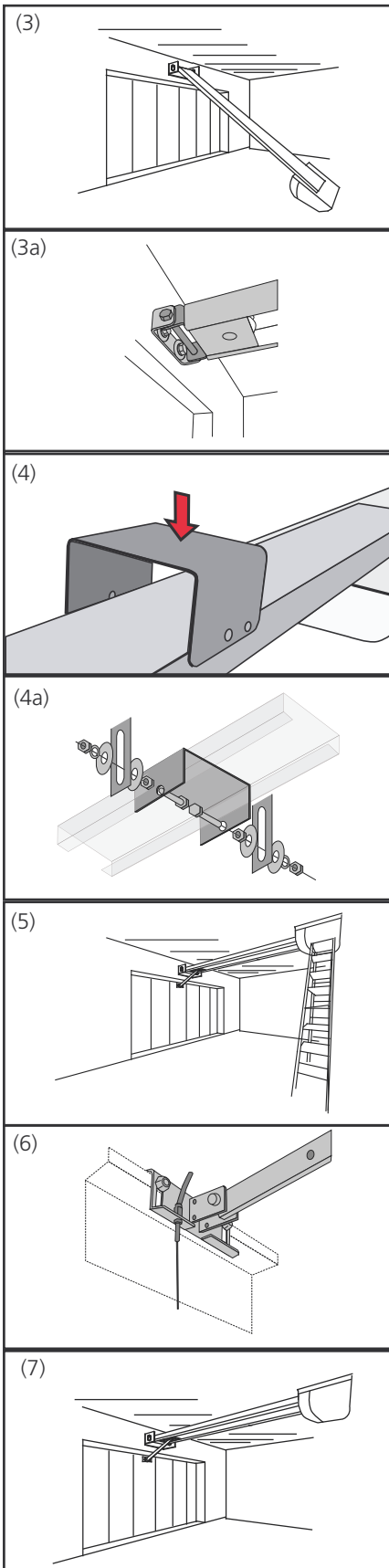

**3.** Attach the C-rail to the front fixing angle (3). Put a carton piece under the motor head unit to avoid damages.

**4.** To fix the motor head to the ceiling we recommend you to use a ladder (4). When the operator is laying on the ladder you can open the garage-door. Adjust the C-rail according to the mark you made in the middle of the garage-door.

Fix the operator to the ceiling when you have made sure the C-rail is running straight to the front. Use the supplied bracket to fix the C-rail to the ceiling (pic. 4 and 4a).

**5.** Now fix the door arm to the garage door (6). Take care that the angle between the operator and the door arm does not exceed a max. of 45° (it may be lower).

**6. The limit-blocks must be tightened before running the operator!**

**The garage doors' bolts must be removed before running the operators - otherwise damages on the garage door or operator might occur!**

For additional security our locking set can be obtained as an optional extra.

## Adjusting the running-length blocks

These adjustments **must** be made **before the programming of the forces and the running-length.**

**Starting the programming procedure without correctly adjusted blocks may lead to damages on the garage door and the operator!**

Vorgehensweise:

1. The operator is mounted and the door-arm is fixed to the garage-door. The trolley is locked to the chain and stands somewhere between the two blocks. If, however, trolley and chain need to be moved you may do this using the TEST/RUN button.
2. Release the trolley (Pic. 1) and manually close the garage door.
3. The block for the closing direction is now right in front of the trolley (Pic. 2). If not, the block must be moved until it touches the trolley.
4. Tighten the blocks' screw to keep it in place. Take care not to tighten it too strongly - the c-rail should not be bended.
5. Now the garage door needs to be opened manually. The trolley will lock into the chain - you have to release it once again to fully open the garage door. (Pic. 1).
6. The block for the opening direction is now right in front of the trolley (Pic. 3). If not, the block must be moved until it touches the trolley.
7. Tighten the blocks' screw to keep it in place. Take care not to tighten it too strongly - the c-rail should not be bended.

### **8. The trolley now needs to be locked back to the chain!**

After that the programming procedure may be started (page 10 onwards).

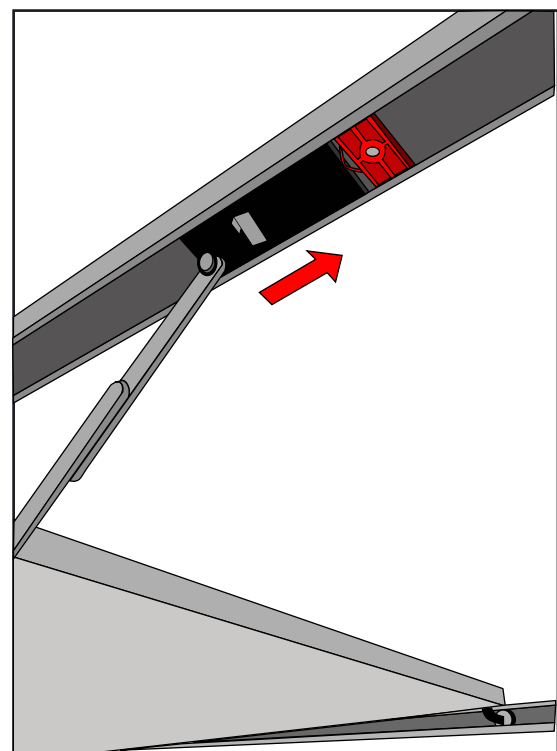
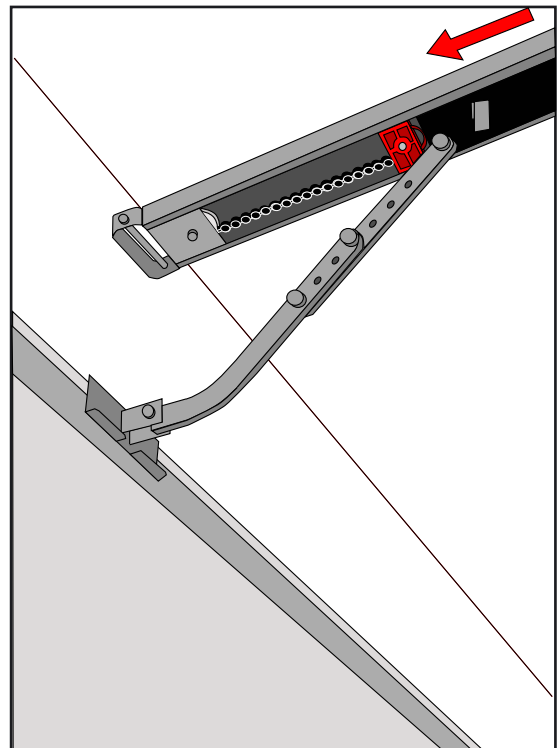
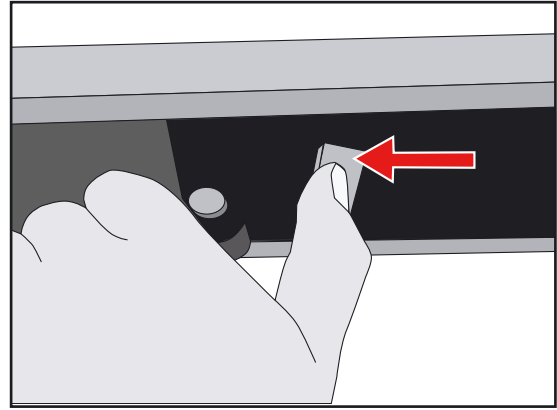

## The Emergency Release

Pic. 1

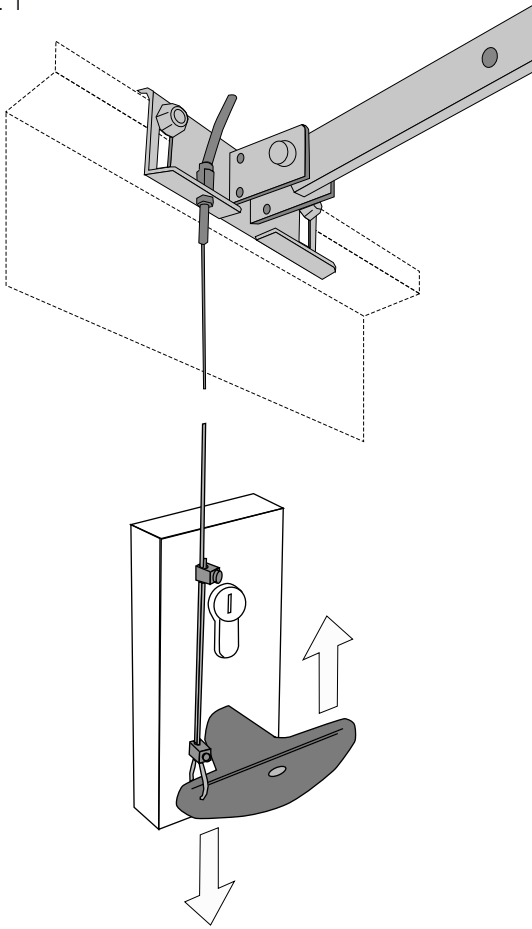

In case of a power failure the garage door can be opened by hand. Therefore the operator first needs to be released.

### When the garage door is the only entrance

It is necessary to connect the emergency release to the door's handle (pic. 1) otherwise the garage cannot be accessed in a power failure situation.

Proceed as follows:

1. Find out in which direction the door handle moves when opening the door.
2. Drill a hole in that side of the door handle which turns downwards.
3. Thread the cable through the hole and fix it with the enclosed metal-clamps. Be careful not to put a high tension on the emergency release cable - the operator then might release from the garage-door during a normal opening cycle.
4. Check the function of the emergency release together with a second person. Stay inside the garage and close the door with the operator. Let the second person open the door manually with the door keys. If this works, the emergency-release is mounted properly.

**Do not leave the garage and close the garage-door with the operator before you have tested the emergency-release!**

Pic. 2

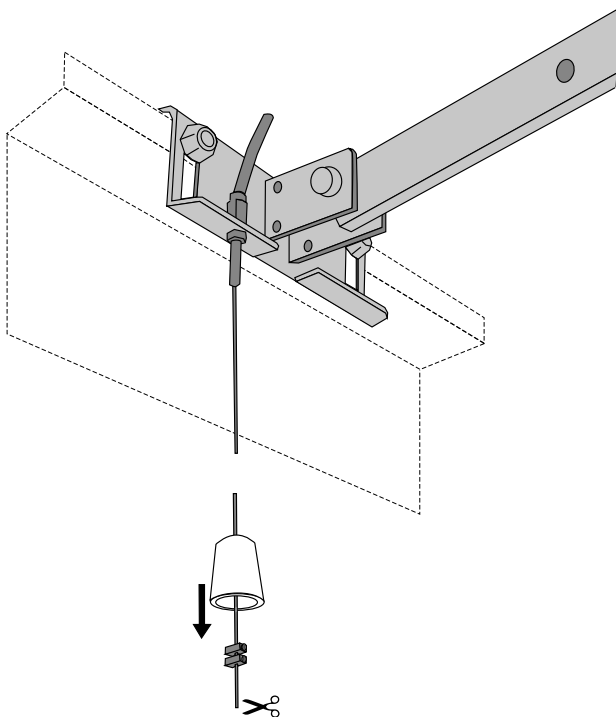

### When there is a second entrance to the garage

You can use the supplied handle for the emergency release (pic. 2).

Thread the emergency release cable through the handle.

Fix the metal clamps to the cable where the handle shall be placed.

Shorten the cable below the metal clamps - the handle is now being held by the clamps.

In case of a power failure the user can now open the garage door by releasing the operator with the handle for the emergency release.

## Devices for Adjustments

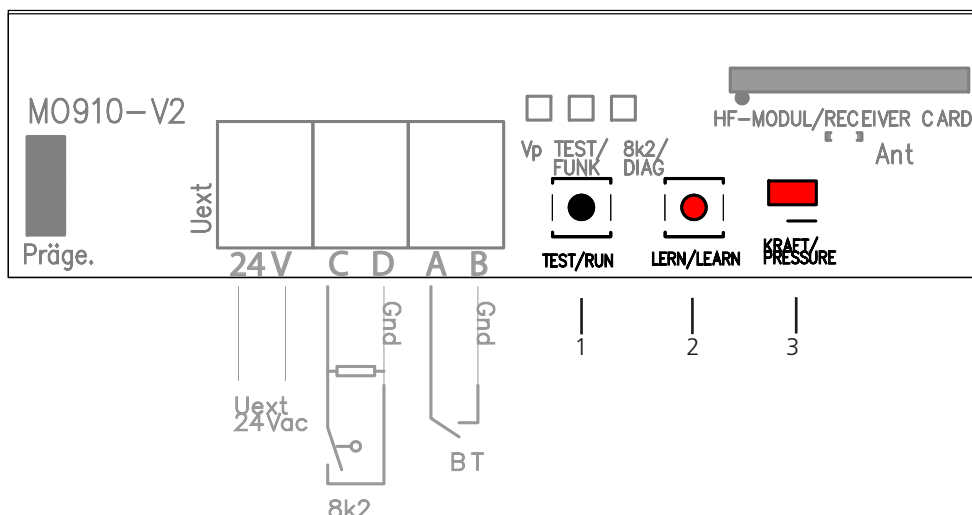

**This page only shows the functions of the buttons and potentiometers on the P.C.B.. To programme the operator please refer to page 10 onwards.**

### TEST/RUN-Button (1)

With this button you put the operator into operation. The button works on the OPEN-STOP-CLOSE principle, e.g. the first push opens the door, the second push stops the door and the third push closes the door etc.

The LED-lamp "TEST" is switched on as long as you press the TEST-button and shows that the impulse was received and recognised by the electronics.

### LERN/LEARN-Button (2)

This button has two functions:

1. Learning the forces
2. Registering (learning) a hand-transmitter
3. Starting advanced programming functions

The LERN/LEARN-button must be pressed for approx. 3 sec.; the button can be released once the operator's light starts blinking. Whilst the operator's light is blinking you can either register a new hand-transmitter by pushing the hand transmitters button OR you may start the learning of forces by pressing the button once again.

Details on both procedures can be obtained from the chapters "Automatic Force Setting" on page 11 and "Remote Control" on page 15.

### Jumper "KRAFT/PRESSURE" (3)

With this Jumper the operators' force is slightly increased:

- Jumper is plugged on: higher force (standard setting)
- Jumper is removed: lower force

When removing the jumper the operator will react more sensitive to obstacles; it might also react to heavy winds. Therefore we recommend to leave the jumper plugged on in areas where strong winds are expected frequently.

Both jumper settings provide full compliance with the entire force limits regulated by EC-directives.

### Combined TEST + LERN button functions

Through a combined use of TEST and LERN button the following special functions can be adjusted:

1. Pre warning light
2. Duration of the internal light

How to adjust these functions is explained on page 12 "Special Functions".

## Programming Running-Length and Force

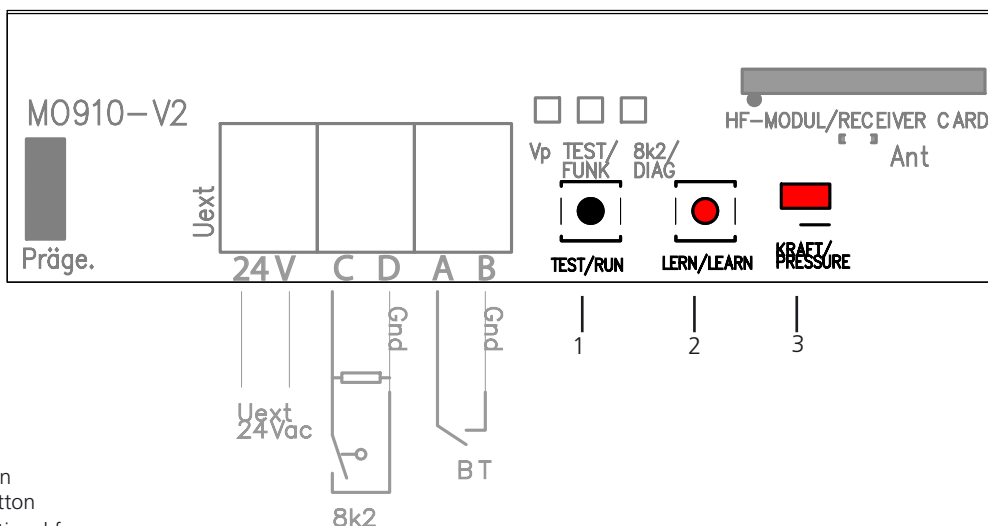

Pictures:

- 1: TEST/RUN-Button
- 2: LERN/LEARN-Button
- 3: Jumper for additional force

### Information

To properly use the operator it is necessary to programme the running-length and the force. **Using the operator without these important adjustments may lead to damages on the garage door and the operator. For test-runs without a garage door the running-length blocks must be tightened (please refer to page 8 "Adjusting the running-length blocks").**

The programming procedure is done completely automatic with an automated procedure. The programming-mode needs to be started first - it will be indicated by the blinking operators' light.

The quick-reference on this page shows a short summary of the procedure.

#### 1.) Adjusting the running-length blocks

This step is described on page 8, "Adjusting the running-length blocks". (Remark: *the blocks are fixed by tightening the screw*).

#### 2.) Starting the programming-mode

Keep the LERN/LEARN button (2) pressed for 3 seconds - release it once the operators' light begins blinking. The operator is now running in programming-mode.

#### 3.) Start the learning-cycle

Shortly press the LERN/LEARN button (2) once again. The operator now starts three fully automatic measurement-runs:

- 3.1. First the block for OPENING direction is searched for
- 3.2. Second the operator closes the garage door with low speed (during this run you may also change the length of the factory pre-set soft-stop).
- 3.3. The operator stops when the garage door is closed - the measured running-length is now stored in the memory
- 3.4. The operator opens the garage door and measures the required opening-force
- 3.5. The operator closes the garage door and measures the required closing-force
- 3.6. The operator stops in closing position and remains blinking for a couple of seconds.

Once all the measures values have saved in the memory the operators' light stops blinking - now the operator is ready for use.

Proceed with the programming of hand-transmitters on page 15.

### Quick Reference

#### 1.) Adjustment of blocks

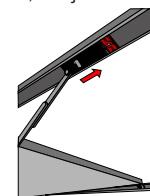

The running-length blocks for opening and closing direction must be properly adjusted (please refer to page 8)

#### 2.) Start programming mode



Press the LERN/LEARN button for approx. 3 seconds. The operators' light begins blinking - release the LERN/LEARN button

#### 3.) Start the learning-cycle



Press the LERN/LEARN button once again shortly: the operator now starts three fully automatic measurement-runs.

The learning cycle stops after the three runs. The garage door is then closed and the operators' light stops blinking. The programming is now complete.

4.) You may now proceed with chapter "Remote Control" on page 15

## Special Functions

### Readjusting the CLOSING soft-stop

The TM60 is shipped with a factory pre-set length for the soft-stop in closing direction. It might be necessary to extend the length of the soft-stop, especially in cases where the door is slamming in spite of the pre-set soft-stop.

The length of the soft-stop can be adjusted during the first automatic measurement-run in closing direction. Please proceed as described below:

1. the operator is closing the door with low speed
2. press the LERN/LEARN button and keep it pressed - the operator is now increasing the speed
3. release the LERN/LEARN button at the position where the soft-stop shall begin (*the operator will save this position as the beginning of the CLOSING soft-stop*)
4. the operator will reduce speed with a short delay and then reach the closing position
5. the operator will proceed with the remaining measurement-runs

When the operators' light stops blinking, all measured values are saved in the memory - the CLOSING soft-stop now is in the programmed position.

### Readjusting the time for the internal light

The time for the internal light may be adjusted from 10 seconds to 5 minutes. The factory setting is 3 minutes.

To readjust the time proceed as described below:

1. Keep the **LERN/LEARN** button pressed **for 6 seconds. Release** the button once the **green LED „TEST/FUNK“** turns on.
2. **Shortly** press the **LERN/LEARN** button again.
3. The green LED **„TEST/FUNK“** now starts **blinking at 1 second intervals** - each blinking increases the time by 10 seconds.
5. Once the required time is reached, press again the LERN/LEARN button shortly. The value is then saved in the memory - the programming is finished.

LED TEST/FUNK blinks .... times	Time for light is:
6 x	1 minute
12 x	2 minutes
18 x	3 minutes
24 x	4 minutes
30 x	5 minutes

### Setting the pre-warning ON/OFF

1. Keep the **LERN/LEARN** button pressed **for 6 seconds. Release** the button once the **green LED „TEST/FUNK“** turns on.
2. **Shortly** press the **TEST/RUN** button
3. The **green LED TEST/FUNK** indicates whether the pre-warning is switched ON or OFF:  
 LED TEST/FUNK is off: pre-warning is OFF  
 LED TEST/FUNK is glowing: pre-warning is ON
4. by **shortly pressing** the **TEST/RUN** button the pre-warning can be switched ON and OFF
5. after making your choice shortly **press** the **LERN/LEARN** button - the setting will be saved to the operators' memory.

### Quick Reference „CLOSING Soft-Stop“

1.) First measurement-run; the operator is running in closing direction	Press the LERN/LEARN button and keep it pressed- the operator increases the speed.
2.) Operator runs with high speed into closing direction	Release the LERN/LEARN button where the soft-stop is intended to begin
3.) The operator reduces speed and finally stops in closing position. It proceeds with the remaining two measurement-runs. The position of the CLOSING soft-stop is saved as adjusted.	

### Quick Reference „Time for internal light“

1.) Keep the red LERN/LEARN button pressed for 6 seconds	After 3 seconds the operators' light starts blinking, after 6 seconds the green LED „TEST/FUNK“ turns on
2.) Release LERN/LEARN button	LED „TEST/FUNK“ is on
3.) Shortly press LERN/LEARN button	LED „TEST/FUNK“ begins blinking at 1 second intervals. Each blinking adds 10 seconds to the time (starting from zero)
4.) Press LERN/LEARN button shortly when required time is reached	The adjusted time will be saved in the memory.

### Quick Reference „Pre-Warning“

1.) Keep the red LERN/LEARN button pressed for 6 seconds	After 3 seconds the operators' light starts blinking, after 6 seconds the green LED „TEST/FUNK“ turns on
2.) Release LERN/LEARN button	LED „TEST/FUNK“ is on
3.) Shortly press the black <b>TEST/RUN</b> button	LED „TEST/FUNK“ indicates status: LED on: pre-warning ON LED off: pre-warning OFF
4.) Shortly press the <b>TEST/RUN</b> button: pre-warning on/off	By pressing the TEST/RUN button the pre-warning is switched on and off
5.) Shortly press the red LERN/LEARN button	The chosen adjustment is saved into the memory.

## External Connections

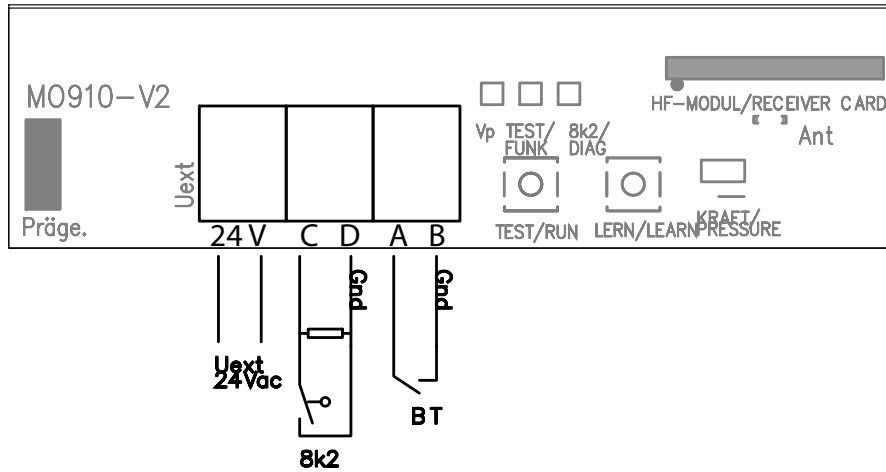

Component	Connector	Function
<b>Push Button and Key Switch</b>	<b>A + B</b>	Floating connector for push button and key switch: no electricity to come into contact with these connectors! When using an external receiver the impulse wires are connected to this terminal.
<b>Photo-Cell</b>	<b>C + D</b> (with 8,2 kOhm resistor)	<p><u>Function</u>                      OPENING direction: when releasing the CLOSING limit-switch the connector is checked for 3 seconds (= hatch door closed or opened). Impulses coming in later during the OPENING cycle will be ignored.                      CLOSING direction: the connector is being checked throughout the whole CLOSING cycle. If an obstacle is recognized (by the security-beam) the operator will reverse</p> <p><u>Hatch-Door Switch</u>                      A hatch-door within the garage door can be secured with a switch - when the switch is not activated (e.g. the hatch-door stands open) the operator will not work.  <b>ATTENTION: when a photo-cell AND a hatch-door switch are connected at the same time, then they must be connected in a row (not parallel)!</b>                      Please also take into consideration, that the hatch-door switch may not be sensitive to the shaking of the garage door during the movement - otherwise it may come to unwanted stops and reversions during the closing procedure!</p>
<b>24V DC Supply</b>	<b>24V</b>	24V DC power supply for external components (external receiver, photo-cell), a maximum of 150 mAmp. is allowed.
<b>Receiver-Module</b>	<b>HF-Modul / Receiver-Card</b>	Plug for Seip remote-receiver cards.

## LED-Lamps

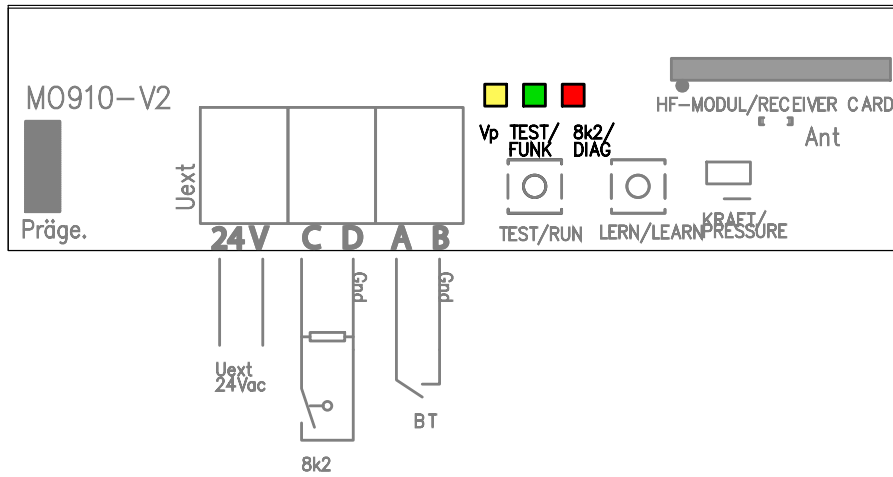

LED	Function	ON	OFF
<b>LED "TEST"</b>	(green) Turns on when: 1.) a device connected to A+B (push-button, key-switch) gives an impulse 2.) the P.C.B.'s TEST-button is pressed 3.) a signal from a registered hand-transmitter is received 4.) the operator is in programming-mode <i>This LED also is being used for the programming of special functions (pre-warning, time internal light)</i>	Incoming impulse	No incoming impulse
<b>LED "Diag"</b>	(red) Turns on when: 1.) a safety-device recognizes an obstacle 2.) a short-cut is detected in the wiring of a security device 3.) a safety-device is not working properly <i>This LED also is being used for the programming of special functions (pre-warning, time internal light)</i>	Incoming impulse from a programmed hand-transmitter	No incoming impulse from a hand-transmitter
<b>LED "Vp"</b>	(yellow) "ON" when mains power supply is o.k.	Mains power supply o.k.	No mains power

## Programming the Hand Transmitters

### Quick reference: programming the first hand transmitter

1.) Keep the LERN/LEARN button pressed for approx. 3 sec.

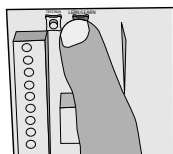

The operators' light will start blinking

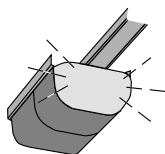

2.) Press the hand transmitter button you want to use



The operators' light stops blinking - the transmitter was successfully programmed

### Quick reference: Programming additional hand transmitters from a distance

*Remark: additional hand transmitters can be programmed either like the first transmitter or from a distance as explained below:*

1.) Open the garage door for approx. 50 cm and close it again

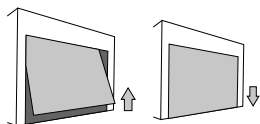

After the garage door is closed you have got 10 seconds to proceed to step 2)

2.) Press buttons 1+2 simultaneously on any **registered** transmitter for 3 sec.



The operators' begins blinking - release the hand transmitters' buttons

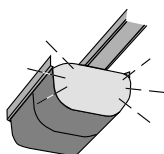

3.) Take the **new** hand transmitter and press the button you want to use shortly



The operators' light stops blinking - the hand transmitter was successfully programmed

### Basics

As a standard the operator is equipped with a 433 MHz AM remote control set. The coding is done via rolling code - the code is changed after each impulse; receiver and transmitter agree completely automatic about the next code to be used. New codes will be chosen out of a pool of billions of possible codes.

Your operator is equipped with our standard remote control set when you hand transmitters looks like the one shown on the right hand side. The 4-channel MIDI transmitter is standard equipment, the 2-channel MINI transmitter is available as an optional.

If your operator is equipped with another remote control set, please refer to the manufacturers instructions for programming.

### Programming Transmitter and Receiver

To use a hand transmitter it must first be registered (programmed) by the receiver. Only one hand transmitter button can be used for one receiver.

### Registering the first hand transmitter

The first hand transmitter (e.g. no hand transmitter has been registered for the receiver, yet) must be learned directly via the operators' main electronic:

1. Press the LERN/LEARN button on the main electronic for approx. 3 seconds until the operator's light starts blinking and release the LERN/LEARN button.

2. Press the hand transmitter button you want to register to the receiver - the operators' light stops blinking when the transmitters' signal was received. The transmitter is now registered.

### Registering additional hand transmitters

When at least one hand transmitter has been registered by the receiver you may program additional hand transmitters from a distance:

1. The garage door must be closed

2. Open the garage door approx. 50 cm and close it again.

3. After the garage door is closed you have got 10 seconds to press the buttons 1+2 simultaneously on the registered hand transmitter - the operator's light then starts blinking.

4. The light will keep blinking for another 10 seconds - during that period of time you must press the button on the new hand transmitter which you want to use with the operator. Once the new transmitter is registered the operator's light stops blinking.

The procedure must be repeated for each new hand transmitter.

### Clearing the receivers' memory

Keep the LERN/LEARN button pressed for approx. 15 sec.. The operators' light and the red LED „Diag“ will start blinking after 3 seconds. After another 10 seconds the red LED „DIAG“ will glow constantly. You can then release the LERN/LEARN button.

**All previously programmed hand transmitters are now cleared from the receivers' memory.**

## Additional Information

4-channel MIDI transmitter,  
433 MHz, rolling code

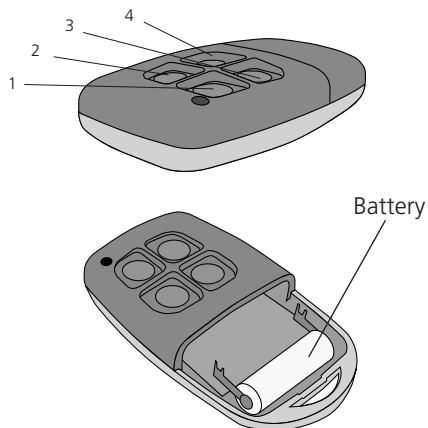

**Usable types of batteries: A23, 23A, 23L, EL12, VR 22 and MN 21**  
**Voltage: 12V**  
**Used batteries must be disposed of according to national laws!**

2-channel MINI transmitter (optional extra),  
433 MHz, rolling code

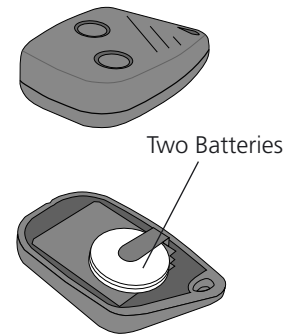

**Two batteries, type CR1616 or DL1616 are required.**  
**Voltage: 2\* 3V (=6V)**  
**Used batteries must be disposed of according to national laws!**

### Criteria influencing the range

*The TS operators are equipped with a high quality remote control set as a standard!*

Nevertheless the remote control is the part of the operator which might be influenced by circumstances in the surroundings of the garage. With our standard remote control you might reach a range of more than 100 meters. In areas with high disturbances the range will still be approx. 50 meters.

The range might be influenced by:

- old batteries in the hand transmitter - if you should experience a problem with the range, please change the batteries first. The lower the batteries run the lower the range will be.

- Building materials of the garage  
In a garage made of concrete and steel you might reach a lower range than in an ordinary garage build of stone. The more steel was used for the walls the shorter the range of your remote-control.

Remote-control activity in the area  
Radio and television transmitters close to your garage might reduce the range.

Older baby-phones  
Especially older baby-phones might influence the range of the remote control severely. These devices send strong signals via the houses internal power supply net. These signals also intrude other devices via the wall plug, as eg the operator.

It is extremely unlikely that the range will drop to an unacceptable distance. If, however, problems should occur we will like to be helpful.

### Use with a HomeLink® System

The HomeLink® System is becoming more and more popular in private households. Most frequently it is being used in cars - the HomeLink® module is integrated in the car. It allows the driver to activate the door operator with a push of button which is installed in his car. Once programmed, the driver does not need the hand transmitter to access the garage with his car.

The standard remote control supplied with the TS-series is compatible with HomeLink® systems manufactured by end of year 2002 / beginning of year 2003 (subject to technical alterations).

The procedure how to program the HomeLink® device is described in the car's manual - please refer to those instructions. *(Basic information on programming: you first must register the hand transmitter with the operator. The HomeLink® system will then learn the code from the hand transmitter).*

**Please avoid to drop the hand transmitter - parts could be damaged inside the transmitter. That might lead to malfunctions!**

## Technical Data

	<b>TM 60</b>
Maximum Pulling Force (adjustable)	60 kg (+/- 4%)
Force-Setting for Operation	automatic
Motor	24V DC, low-noise
Running Speed	14 cm/sec.
Speed in Soft Mode	8 cm/sec.
Lighting	230V AC, max. 40 watts
Lighting Durance (adjustable)	10 to 300 seconds
Duty Cycle	80%
Power Consumption in Stand By	2,3 watts

Power Supply	190-250V AC
Transformer	230V AC, 24V DC
Pre-Warning Light	adjustable
Soft-Stop in Closing Direction	adjustable
Nett Running Length	2.640 mm
Max. Running Length with Extension	4.050 mm
Overall Length	mm
Height Motor Head	mm
Length Motor Head	mm
Width Motor Head	mm
Minimum Space above the door	35 mm
Weight including packaging	kg

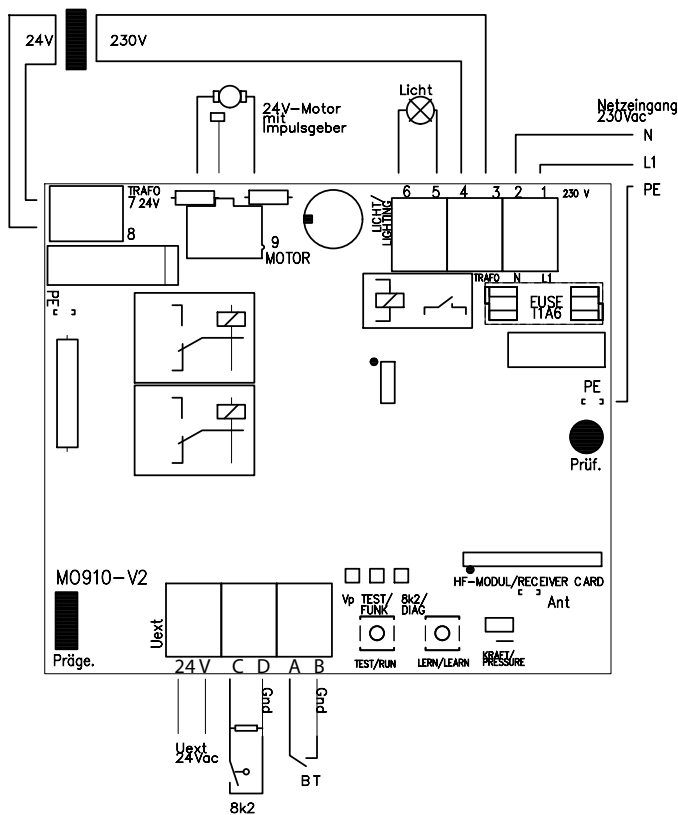

## Wiring

### Internal Wiring

1	Blue, mains supply, 230V
2	Brown, mains supply, 230V
3	Black, transformer, 230V
4	Black, transformer, 230V
5	Brown, Lighting, 230V
6	Blue, Lighting, 230V
7	White, transformer, 24V
8	White, transformer, 24V
9 MOTOR	Connector for the plug from the motor
PE	Earthing from the printed circuit board to the base plate
Earthing of the mains supply	The earthing of the mains supply (green/yellow) is connected to the base plate with a screw (the screw is marked with a earthing symbol)

### External connections

(Explained on pages 12 + 13)

A + B	Floating connector for push-button, key-switch and the impulse cables of an external receiver
C + D	Floating connector with a 8,2kOhm resistor for impulse cables from a photo-cell receiver
24V	24V DC for a photo cell transmitter when a self test before every movement of the door is required

### Devices for adjustments

Button „Test/Run“	Runs the operator - OPEN-STOP-CLOSE
Button „Lern/Learn“	For automatic force setting and registration of hand transmitters
Jumper „FORCE/PRESSURE“	Setting of lower or higher force

### Others

HF-Modul/Receiver Card	Plug for receiver module, 433 MHz
FUSE	Fuse T1,6, 250V

# Troubleshooting

## Error Messages

The TM 60 is equipped with a system of error messages via the internal lighting and the LED "Diag".

### Error messages via the operator's light

#### 2 x blinking

Running-time error - the operator did not reach the running-length block within the programmed distance. Check the blocks and try reprogramming the P.C.B. (e.g. start the learning-cycles)

#### 4 x blinking

The microprocessor has lost data - try to run the learning cycle. When this does not work, the motor-head needs to be replaced.

#### 5 x blinking

The microprocessor cannot save data - the P.C.B. shuts down and stops all operations. The motor-head needs to be replaced.

#### 6 x blinking

Damaged relays - the electronics need to be exchanged

### Additional messages only via the LED "Diag"

#### 3 x blinking

Photo cell - either an obstacle was recognised by the photo cell/hatch-door switch or one of the devices is damaged. Please also check the wiring.

## If... then...

### The operator does not react on the transmitter or on the push-button switch

Power failure? Disconnect and connect the operator. Is the door stuck because of snow and ice? Check the lines and the connections of the push-button switch. Is there water in the push-button switch or in the key operated switch? Disconnect alle external components and try running the operator via the TEST/RUN button.

### The operator reacts on the transmitter but not on the push-button switch

Check the line of the push-button switch. Does the push-button switch work, when the remote receiver is disconnected? If so, the remote transmitter or receiver might be defective.

### The operator reacts on the push-button but not on the transmitter

Check the accordance of the transmitter and the receiver code. Displace the antenna of the receiver. Avoid each metal contact (reduces the range). Check the battery of the transmitter

### The operator neither reacts on the push-button nor on the transmitter

Disconnect the receiver or remove the transmitter battery. Use your push-button switch only. If this solves the problem, your transmitter may be defective. Disconnect the push-button switch and use your transmitter only. If this solves the problem, the push-button switch or the line of the push-button switch may be defective.

### The door doesn't open completely

Is the limit switch „OPEN“ correctly set? Is the door jamming while opening? Unlock the carriage manually (make the door running well). Lubricate and oil the pivotal points of the door. Increase the power.

### The door doesn't close completely and opens again

Is the limit switch „CLOSE“ set correctly? Is the door jamming while closing? Unlock the carriage manually (make the door running well). Lubricate and oil the pivotal points of the door. Run through the automatic learning cycle.

### The emergency release doesn't work

Is the limit switch „CLOSE“ correctly set? If not, your opener switches off under pressure. In this case the chain is under tension and therefore the emergency release can hardly be unlocked. Make sure that the limit switch is correctly set.

### The light doesn't work

Replace the bulb (230 V, max. 40 Watt)

### The operator isn't running smooth

Unlock the carriage of the opener. Move the door manually and make sure that the door is well balanced (must come to a stop at each position). The spring tension is too high or there is even a spring fracture.

### The motor is buzzing but the door doesn't move

The door is jamming.

### The operator works, but the door doesn't move

The carriage is unlocked. If you want to lock it, open the door, but not completely, and let the opener run. The carriage locks in automatically.

### The operator doesn't work because of a power failure

Unlock the carriage with the help of the emergency release and open the door manually. (If you have a garage where you can only enter from outside: Unlock the door with the key and turn the door-handle, then your opener will be unlocked. If you have a garage where you can also enter from inside: pull at the Bowden cable hanging from the carriage.)

**EC Declaration of Conformity**

Low-Voltage Directive 73/23/EEC

and amendments

Electro-Magnetical Compatibility 89/336/EEC

and amendments



Document No. AN-16062003

Dokument Nr. AN-16062003

**EG-Konformitätserklärung**

im Sinne der EG-Richtlinien

Niederspannungsrichtlinie 73/23/EWG

mit Änderungen

Elektromagnetische Verträglichkeit 89/336/EWG

mit Änderungen

We,

Wir,

**Seip Antriebstechnik GmbH****Grombacher Straße 83, 75045 Walzbachtal-Jöhlingen, Deutschland**

hereby declare, that the following products comply to the mentioned EC-regulations.  
*erklären hiermit, daß die nachfolgenden genannten Produkte den unten angegebenen  
 EG-Richtlinien entsprechen.*

Type of Product / Produktart	Garage Door Operator / Torantrieb
Product Name / Modell	TM 60
Approved according to 89/336/EEC and 73/23/EEC / Geprüft nach 89/336/EWG und 73/23/EWG Referring EC-regulations: / Angewandte harmonisierte Normen:	
<b>Electromagnetic Compatibility /    Elektromagnetische Verträglichkeit</b>	<b>EN 61000-3-2:2000</b> Limits for harmonic current emissions / Grenzwerte für Oberschwingströme <b>EN 61000-3-3:1995 + Corrigendum:1997 + A1:2001</b> Limitation of voltage changes, voltage fluctuations and flicker in publik low-voltage supply systems / Grenzwerte für Spannungsschwankungen und Flicker <b>EN 61000-6-3:2001</b> Emission standard for residential, commercial and light-industrial environments / Störaussendung für Wohnbereich, Geschäfts- und Gewerbereiche sowie Kleinbetriebe <b>EN 61000-6-2:2001</b> Generic standards - Immunity for industrial environments Fachgrundnorm - Störfestigkeit - Industriebereich
<b>Low-Voltage Directive /    Niederspannungsrichtlinie</b>	<b>EN 60335-2-95:2001-7</b> Particular requirements for drives for vertically moving garage doors for residential use / Anforderungen für Antriebe von Garagentoren mit Senkrechtbewegung zur Verwendung im Wohnbereich <b>EN 60335-1:1994 + A1:1996 + A2:2000 + A11:1995 + A12:1996 + A13:1998 + A14:1998 + A15:2000 +    A16:2001</b> Safety of household and similar electrical appliances / Sicherheit elektrischer Geräte für den Hausgebrauch
<b>Safety in Use /    Nutzungssicherheit</b>	<b>EN 12453:2000</b> Safety in use of power operated doors, requirements / Nutzungssicherheit kraftbetätigter Tore, Anforderungen <b>EN 12445:2000</b> Safety in use of power operated doors, Test methods / Nutzungssicherheit kraftbetätigter Tore, Prüfverfahren

Peter Seip, Geschäftsführer, Walzbachtal-Jöhlingen, 16.06.2003

Grombacher Straße 83  
 75045 Walzbachtal-Jöhlingen  
 Germany  
 www.seip.com

**EC Declaration of Conformity**  
in accordance with the Radio and Telecommunications  
Terminal Equipment Act (FTEG) and Directive 1999/5/EC  
(R&TTE Directive)

**EG-Konformitätserklärung**  
gemäß dem Gesetz über Funkanlagen und Telekomm  
unikationsendeinrichtungen (FTEG) und der Richtlinie  
1999/5/EG (R&TTE)

Document No. FU-16062003  
Dokument Nr. FU-16062003



We,  
Wir,

**Seip Antriebstechnik GmbH**  
**Grombacher Straße 83, 75045 Walzbachtal-Jöhlingen, Deutschland**

declare that the product  
erklären, daß das Produkt

**SKR 433**

Code B43A023004

**Hand Transmitter as remote control for garage door operators**  
**Handsender als Fernbedienung für Garagentorantriebe**  
(Short Range Device)  
(Funkgerät geringer Reichweite (SRD))

complies with the essential requirements of §3 and the other relevant provisions of the FTEG (Article 3 of the R&TTE Directive), when used for its intended purpose.  
*bei bestimmungsgemäßer Verwendung den grundlegenden Anforderungen des §3 und den übrigen einschlägigen Bestimmungen des FTEG (Artikel 3 der R&TTE) entspricht.*

§3(1)1, (Article 3(1)a) does not refer to this type of product.  
*§3(1)1, Artikel 3(1)a bezieht sich nicht auf diesen Produkttyp, es gibt hierzu keine Norm*

Protection requirement concerning electromagnetic compatibility §3(1)(2), (Article 3(1)(b))  
*Schutzanforderungen in Bezug auf die elektromagnetische Verträglichkeit §3(1)2, Artikel 3(1)b))*

**EN 300 220-1/1997**  
**EN 300 683/1997**  
**EMV / EMC Directive 89/336/EEC;92/31/EEC;93/68/EEC**

Peter Seip, Geschäftsführer, Walzbachtal-Jöhlingen, 16.06.2003

**Seip** GmbH  
**ANTRIEBS | TECHNIK**

Grombacher Straße 83  
75045 Walzbachtal-Jöhlingen  
Germany  
www.seip.com